

RECORD MACHINE DETAILS

MODEL
SERIAL No
DATE of PURCHASE
VOLTAGE
PHASE
CYCLES

QUOTE THIS INFORMATION
WHEN REQUESTING SERVICE
OR SPARES.

DISTRIBUTOR

This Machine is engineered to a high standard of construction and performance. Attention to maintenance and service will be repaid by many years' trouble-free operating. Consult your Distributor in the event of difficulty or servicing requirements. Your Distributor is qualified to advise on the proper maintenance of your Machine to assess any claims under the Warranty and to supply and fit genuine STARTRITE parts.

STARTRITE®

Model 351

(SINGLE SPEED)

BANDSAWING MACHINES

HANDBOOK

35E

A.L.T. Saws & Spares Ltd

Startrite Machine Specialist

Unit 15, Pier Road Industrial Estate

Gillingham

Kent

ME7 1RZ

Tel/Fax: 01634 850833

lee@altsawsandspares.com

www.altsawsandspares.co.uk

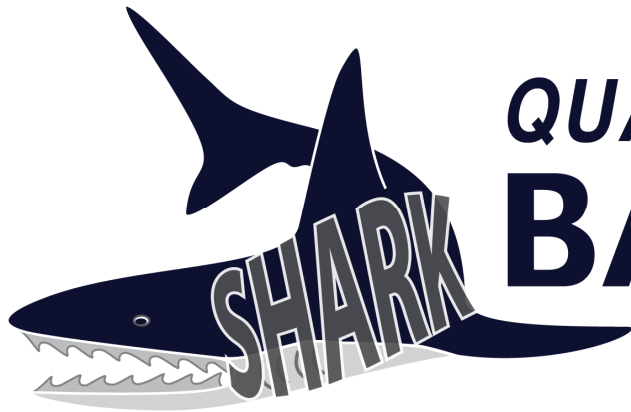

**QUALITY
BANDSAW
BLADES**

TO SUIT THE 351 MODEL

ORDER LINE- 01634 850833

A.L.T. SAWS & SPARES LTD

Unit 15, Pier Road Industrial Estate

Gillingham

Kent

ME7 1RZ

www.altsawsandspares.com

A.L.T. SAWS AND SPARES LTD



PART NUMBER STRG – UPPER – £82.50+vat
 PART NUMBER STRG – LOWER – £79.50+vat

These precision roller guides are manufactured in the UK specifically for the older Startrite models 301 – 351 – 352, refer to the chart below for all models and recommended blade widths.

There is NO drilling, filing or any modification required unlike many cheap after market guides currently on the market.

Manufactured in steel and aluminium, these guides will make a very good saw even better, they give superb blade control have low heat generation to the blade and produce no sparks.

Both side support rollers and thrust roller are adjusted by a cam system giving precision setting longer, and allows full contact to the blade, this eliminates any blade twist, cutting contours will particularly appreciate the blade control.

Although available as upper and lower guide assemblies some customers may only wish to change the upper set as this takes on 80% of the work.

STARTRITE MODEL	STRG – UPPER RECOMMENDED BLADE WIDTH		STRG – LOWER RECOMMENDED BLADE WIDTH	
	MAX	MIN	MAX	MIN
301,301E,301S	5/8"	1/4"	1/2"	1/4"
351,351E,351SE,351S	3/4"	1/4"	1/2"	1/4"
352,352S	3/4"	1/4"	1/2"	1/4"
RS1 (Sold Under The Record Power Range)	5/8"	1/4"	1/2"	1/4"
RS2 (Sold Under The Record Power Range)	3/4"	1/4"	1/2"	1/4"

ALL DIMENSIONS APPROXIMATE.

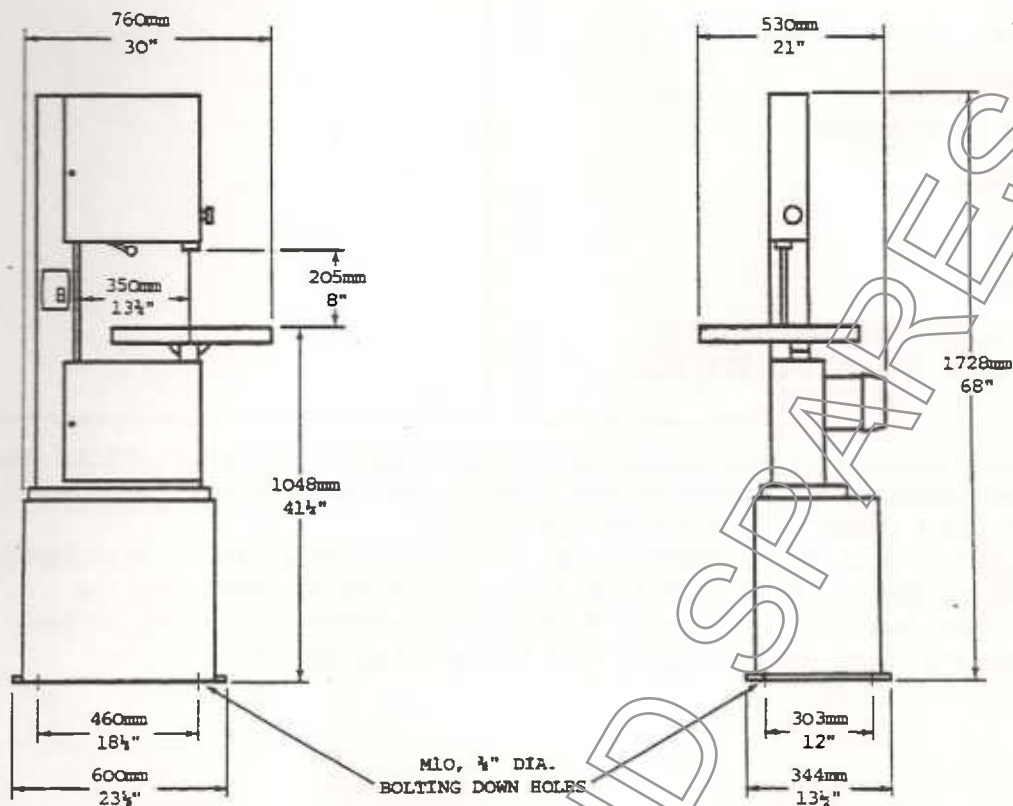

FOUNDATION PLAN FOR MODEL 351 BANDSAWING MACHINE.

SPECIFICATION :

- | | |
|------------------|--|
| Model 351 | - Single Speed Bandsawing Machine |
| Blade Speed | - 915 m/min., 3000 ft/min. |
| Wheel Diameter | - 355mm, 14" |
| Motor | - 0.75kw., 1 h.p., 2850 r.p.m. |
| Electric Supply | - 220/240 Volt 1 Phase 50Hz.
380/440 Volt 3 Phase 50Hz. |
| Blade Length | - 2590mm, 102" |
| Max. Blade Width | - 20mm, 3/4" |
| Weight | - 94 Kg, 207 lbs. |

FOR BEST RESULTS USE 'STARTRITE' SAW BLADES.

WHEN ORDERING PARTS, PLEASE STATE:-

1. Quantity required.
2. Part No. (where applicable) and description.
Specify power supply for electrical components.
3. Machine Model and Serial No.

NOTE: ILLUSTRATIONS MAY VARY IN DETAIL, ACCORDING TO MODEL.

Any machine can be dangerous if improperly used.

Your machine has been designed and manufactured in a way which will provide maximum safety if properly used. Safe working practice is the responsibility of the owner and user and the following rules should be adhered to:

INSTALLATION

The machine should be properly and safely installed, and the work carried out by a competent person in so far as both mechanical and electrical installation is concerned.

OPERATION

1. The operation of the machine should conform to the requirements of the Woodworking Machines Regulation 1974.
2. Safe working practices should be used as given in Health and Safety at Work Booklet No.41 "Safety in the Use of Woodworking Machines" H.M.S.O.

NB: Users outside the U.K. are required to operate to the standards and regulations applicable in their own country.

3. Operators should be fully trained in the safe use of this machine.
4. All guards should be securely in position and doors closed before the machine is started.
5. The machine should be isolated and all movement ceased before making adjustments or removing dust and chips, etc. or before gaining access to electrical components.
6. Tools and cutters used should be those recommended by _____ and should be securely fixed and run at the correct speed. Tools should be sharp and in good condition.
7. No modification to the machine should be made which will reduce safety.
8. The machine should only be used for the purpose for which it is intended.
9. Appropriate protective clothing should be worn.
10. Dust caused during machining of HARDWOODS can be detrimental to health please check with the Health and Safety Executive for details.

MAINTENANCE

For safe operation your machine should be properly maintained. Our Spares and Service Departments are always at your disposal.

A.L.T.

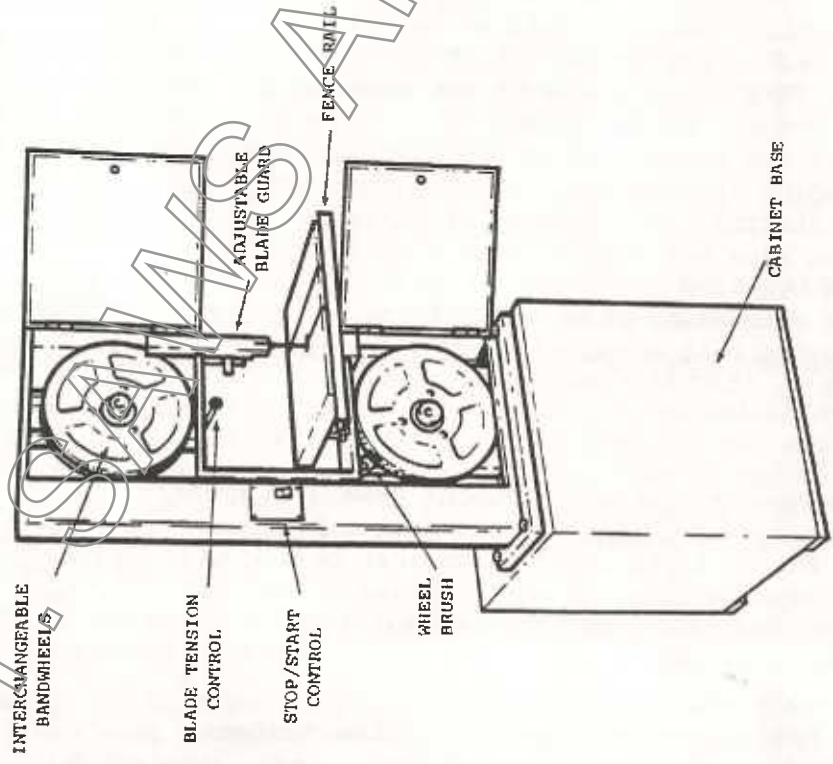
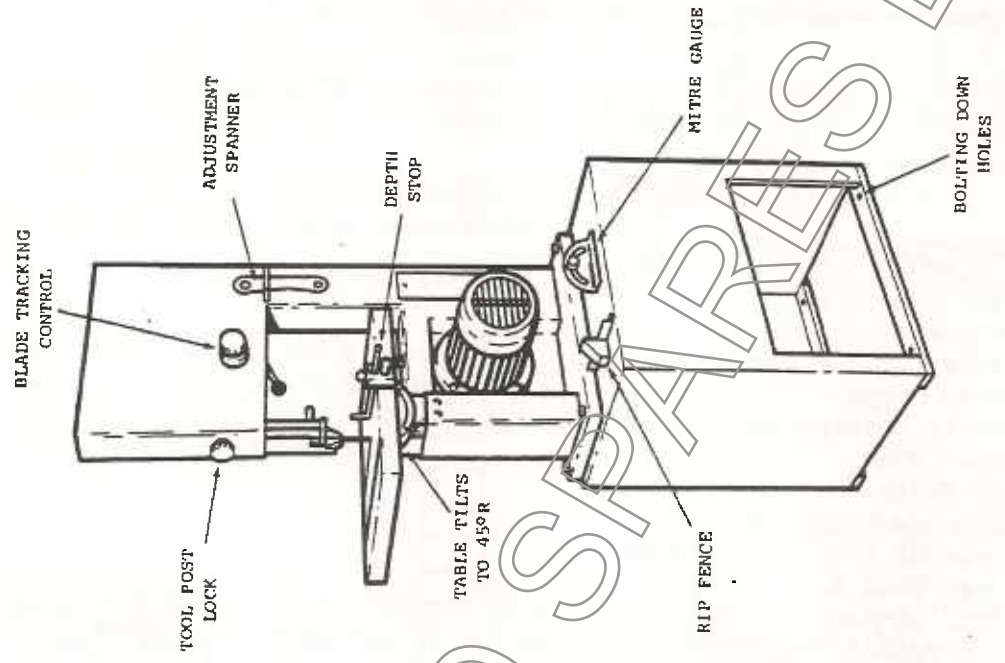

GENERAL LAYOUT OF MODEL 351 BANDSAWING MACHINE.

SPARES LTD

ASSEMBLING BANDSAWING MACHINE.

CAUTION: Motor must not be switched on unless the machine is fully assembled according to the instructions below.

1. Remove contents from carton. Check and identify parts from Check List below before attempting to assemble machine.

CHECK LIST :

Bandsaw Machine
Cabinet Base
Table, Cradle & Fence Rail
Mitre Gauge
Circle Cutting Attachment
Depth Stop
Rip Fence
Adjustment Spanner
4 Hex Hd Screws
4 Hex Nuts
4 Std Washers
4 Shakeproof Washers
4 Special Washers



2. If the machine is to be used without dust extraction proceed to step No.3.
If the Coupling Adaptor (Part No.SM1393) has been ordered to enable the 'CYCLAIR' Extractor Unit to be used with the bandsawing machine, proceed as follows :-

- A. Connect and secure one end of flexible hose to adaptor plate using hose clip supplied.
- B. Place flexible hose through aperture in cabinet base and secure using 4 self tapping screws supplied (see Fig.2).
- C. Secure connecting pipe to other end of flexible hose using clip supplied ready for coupling direct to 'CYCLAIR' Extractor Unit.

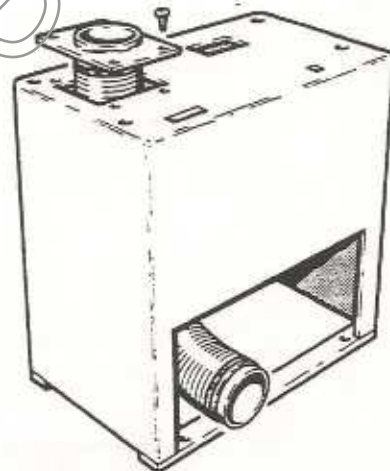

Fig.2.

3. Place bandsaw machine onto cabinet base with front of machine facing plain side of cabinet base as shown in Fig.3. Align holes in cabinet base with holes in bandsaw base and secure using 4 Hex. Hd. Screws, 4 Hex. Nuts and 8 Std. Washers supplied.

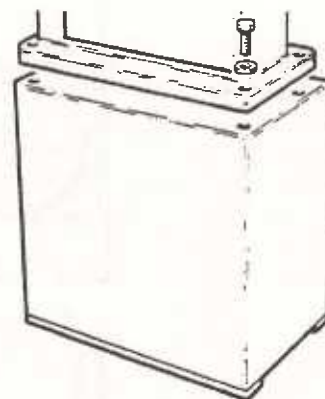

Fig.3.

4. On table locating stud 'A' (see Fig.4), remove hex. nut, std. washer and table clamp.
On underside of table, slacken off four hex. screws 'B' and remove fence rail. Carefully place table and cradle over stud 'A' taking care not to damage the saw blade, and locate cradle onto cradle tilt plates. Secure in place using table clamp (curved edge downwards), washer and hex. nut.

ASSEMBLING BANDSAWING MACHINE (CONTINUED).

5.

Re-assemble fence rail to table, and with 4 hex. screws 'B' (see Fig.4) only hand-tight, place rip fence onto rail so that fence is close to slot in table. Align rail so that fence is true to slot and tighten 4 hex. screws.

NOTE: Fence rail may be assembled projecting either to left or right of the table sides as required.

6.

Secure depth stop to rear edge of table through slot 'C' (see Fig.4) and secure in place using coach bolt, std. washer and wing nut supplied with depth stop.

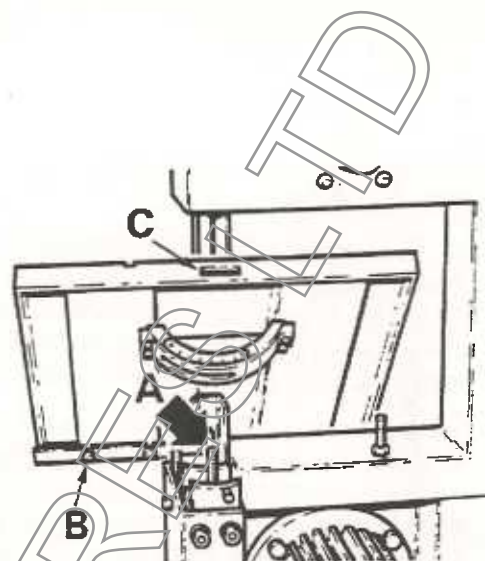

Fig.4.

The machine is now ready to be installed and connected to the electricity supply. Before doing so, read the Operating Safety Precautions below.

OPERATING SAFETY PRECAUTIONS.

BEFORE ATTEMPTING TO OPERATE THE MACHINE, BECOME FAMILIAR WITH THE CONTROLS AND OPERATING INSTRUCTIONS.

Before starting the machine, check that it is safe to do so. Make sure that all guards are in place and keep guards in place when sawing. Never at any time make an adjustment to any part of the machine while the saw blade is in motion.

Adjust and secure table before loading workpiece. Position the top guides as close as possible to the workpiece.

Hold small or unstable workpiece by means of a clamp or other device. Keep hands clear of the saw blade at all times.

Keep the machine table and work area free from tools and off-cuts.

Use only a saw blade that is in good condition and suitable for the work in hand. A saw blade that is distorted, or has mis-shapen teeth is unsafe and should be discarded. Use care in uncoiling and installing new saw blades as the teeth are very sharp. It is advisable to wear gloves when handling saw blades. Do not leave saw blades on the floor.

Always stop the machine before leaving it unattended and isolate machine from mains supply.

Dust Extraction Equipment (Optional Extra) may be advantageous, particularly when some hardwoods are being sawn, to reduce pollution of the atmosphere. Some materials, such as asbestos, give off toxic fumes and dust when machined, and in such cases it is necessary to seek expert advice as to the method of extraction.

INSTALLATION.

Site the machine with adequate working space around it for ease of use. Avoid siting the machine in a cramped corner where operation may prove difficult or near a gangway where a long workpiece may cause an obstruction. The whole working area should be well illuminated and the floor around the machine provided with a level and non-slip surface.

A bench or table space, near the machine to accommodate work in progress will prove a real asset. Bandsaw blades tend to get tangled and damaged if hung from a hook or stacked on the floor, therefore cupboard space provided adjacent to the machine will protect saw blades in storage and encourage the operator to select a suitable saw blade for the job.

The cabinet base is provided with four bolting down holes to accept 10 mm ($\frac{3}{8}$ ") diameter bolts (not supplied). Where bolting down is required, ensure that the machine stands firm and level.

Remove the anti-rust protective coating where applied, and in particular from the working elements of the machine.

CONNECTION TO THE ELECTRICITY SUPPLY.

IMPORTANT : Check that the electricity supply voltage is suitable for operation of the machine. (Voltage stamped on serial plate).

IMPORTANT : IN ALL CASES THE MACHINE MUST BE EFFECTIVELY EARTHED.

The service of a competent electrical engineer must be obtained if there is doubt on any point regarding electrical installation.

SINGLE PHASE.

Recommended cable size : 1.5mm²

Fuse rating : 13 amp

At front of machine remove electrical cover plate by means of four screws (see Fig.5.). Pass supply lead through cable entry nut at rear of machine (see Fig.6) and connect live lead to terminal Ll, neutral supply lead to terminal N and earth lead to terminal E (see Fig.8). Replace electrical cover plate, and tighten gland nut on cable entry nut.

Connection can be made to a 13 amp ring main circuit by wiring the supply lead to a 13 amp fused plug as shown in Fig.7. taking care to protect the cable from mechanical damage.

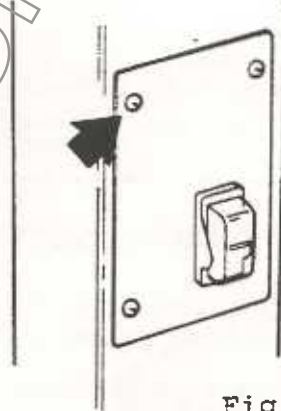

Fig.5.

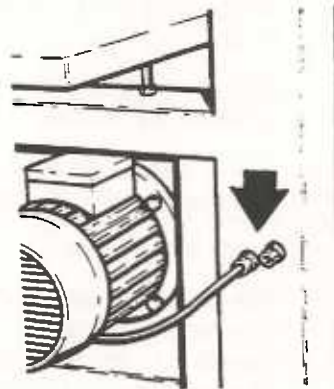
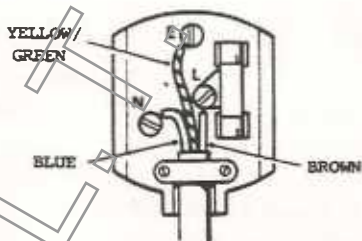

Fig.6.



COLOUR CODE :

LIVE (L) - BROWN
NEUTRAL (N) - BLUE
EARTH (E) - YELLOW/GREEN

Fig.7.

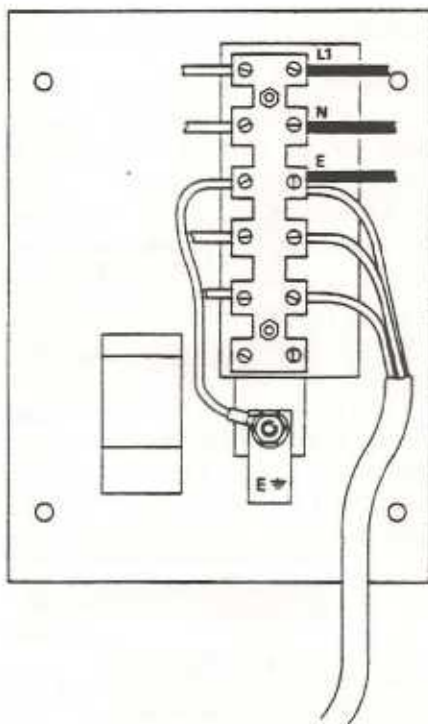

SINGLE PHASE

Fig.8.

BROWN
 BLUE
 YELLOW/
 GREEN

 MAINS
 SUPPLY

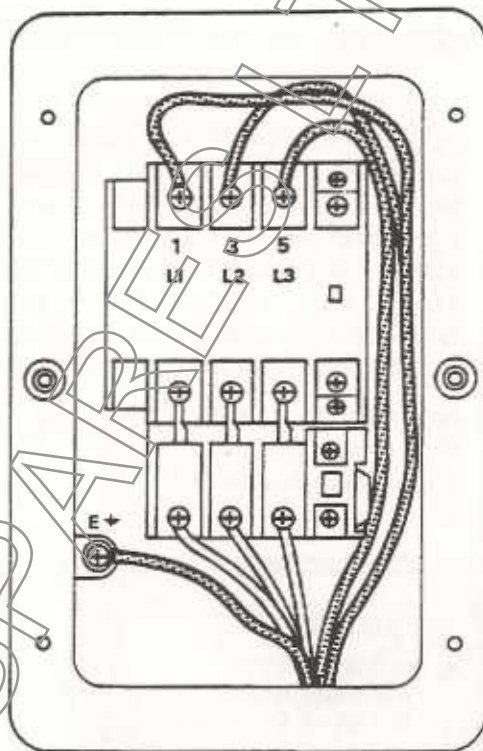

THREE PHASE

Fig.9.

THREE PHASE.

To connect machine to mains supply proceed as follows:- Remove cover of starter (two screws), and complete starter box assembly (four screws). Pass supply lead through cable entry nut at rear of machine (see Fig.6.) and up into starter box through hole provided. Connect mains supply leads to terminals Nos 1, 3 and 5 at top of contactor, and earth lead to earth connection provided (see Fig.9.). Check that the motor rotates in the correct direction, i.e. blade passes downward through the table, and reverse motor rotation if necessary, by interchanging the two supply leads. Re-assemble starter assembly, and tighten gland nut at rear of machine.

OPERATING INSTRUCTIONS.

SETTING UP THE MACHINE/ FITTING A NEW SAW BLADE :

Select a saw blade suitable for the work in hand, see Chart on page 11.
 Open both bandwheel doors, remove upper and lower blade guards and rip fence rail. Lower the top bandwheel by turning the blade tension control handle 'A' (see Fig.8) anti-clockwise and remove saw blade.
 Place selected saw blade over both bandwheels with the teeth facing forward and downward through the table as shown in Fig.9. Apply only sufficient blade tension to remove the slack. It is important that both the top and bottom guides are set back clear of the saw blade so that it is not deflected and follows a true path between the bandwheels.

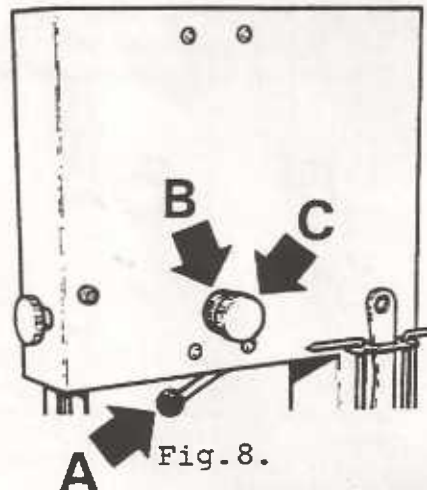

Fig.8.

OPERATING INSTRUCTIONS (CONTINUED)

At rear of machine slacken off knurled locking ring 'B' (see Fig.8). Rotate the bandwheels by hand and at the same time operate the blade tracking control handknob 'C' so that the saw blade runs approximately central on the bandwheels, see Fig.10. When saw blade is tracked correctly hold handknob 'C' and lock using knurled locking ring 'B'.

To tension saw blade simply turn blade tension control handwheel 'A' clockwise until saw blade is taut.

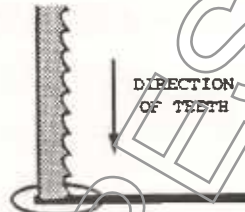
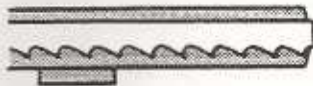
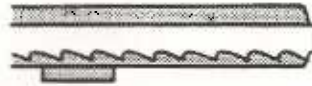

Fig.9.



TRACKING CORRECT
 Blade runs approximately central on bandwheel.



TRACKING INCORRECT
 Blade runs toward front edge of bandwheel.

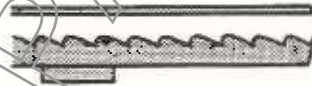

TRACKING INCORRECT
 Blade runs toward back edge of bandwheel.

Fig.10.

When the saw blade is tracking in a satisfactory manner. Turn the blade tension control handle until the appropriate reading appears in the 'window' (see chart below).

EXAMPLE : 12mm (1/2") wide Metal Cutting Blade = MED

BLADE WIDTH	6 mm, 1/4"	12 mm, 1/2"	20 mm, 3/4"
BLADE TYPE	TENSION GUIDE		
METAL CUTTING	LOW	MED	HIGH
WOOD CUTTING, SCALLOPED, KNIFE EDGE	LOW	LOW - MED	MED - HIGH

It is important that the guides are set to offer maximum support to the saw blade without deflection, and to permit maximum engagement with the flanks of the saw blade without snagging the set of the teeth, see Fig.11.

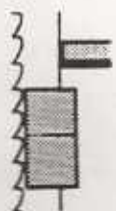

CORRECT
 Maximum support for blade.

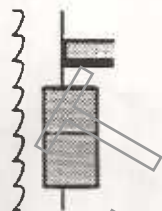

INCORRECT
 Insufficient support for blade from guide.

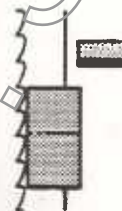

INCORRECT
 Insufficient support for blade from thrust rod.

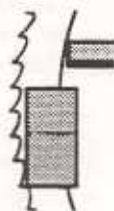

INCORRECT
 Thrust rod deflecting blade.



CORRECT
 Maximum support for blade.

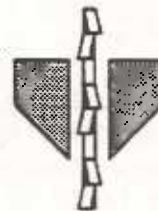

INCORRECT
 Insufficient support for blade.



INCORRECT
 Guide deflecting blade.

Fig.11.

SETTING UP THE MACHINE/FITTING A NEW SAW BLADE (CONTINUED) :

Adjust the guides to support the saw blade in its natural path with the minimum of side clearance (.002" to .004"). A quick and positive method of setting the guides is to position one guide block to just contact the saw blade, then adjust the second guide block to contact the saw blade plus a piece of (single thickness) newspaper.

Set the thrust rod to support the back edge of the saw blade when finger pressure is applied to the blade teeth. There should be a small gap (.010" approximately) between the saw blade and the thrust rod.

After adjusting the top and bottom guides, rotate the handwheels by hand to ensure that the saw blade runs free and that all the adjustments have been correctly carried out.

Replace upper and lower blade guards and close both handwheel doors. Replace rip fence rail with securing screws only hand-tight. Place rip fence onto rail so that fence is close to slot in table. Align rail so that fence is true to slot and tighten securing screws.

TABLE :

The table can be tilted to any angle up to 45°. To tilt table slacken off trunnion nut using spanner provided (see Fig.12). Tilt table and align pointer with protractor scale for required angle and tighten nut. The machine is fitted with a setting stud, make sure the table rests firmly against the stud when re-setting the table to zero.

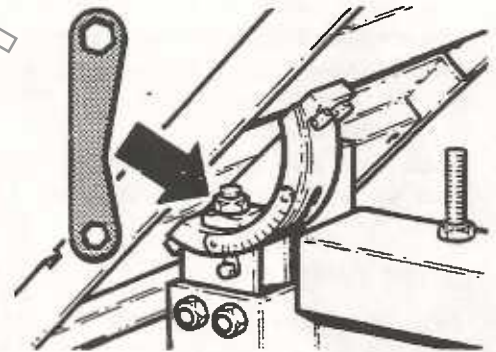

Fig.12.

BLADE GUARDS :

The upper blade guard is fully adjustable and must be kept in position when the machine is in use. The guard height should be set as close as possible to the work piece by means of tool post lock (see Fig.13).

The lower blade guard is designed to give under table protection at all angles of table tilt and must be kept in position when the machine is in use.

TOOLS :

A tool storage bracket is supplied at the rear of the machine (see Fig.13) to accommodate the adjustment spanner, depth stop rod and circle cutting rod when not in use.

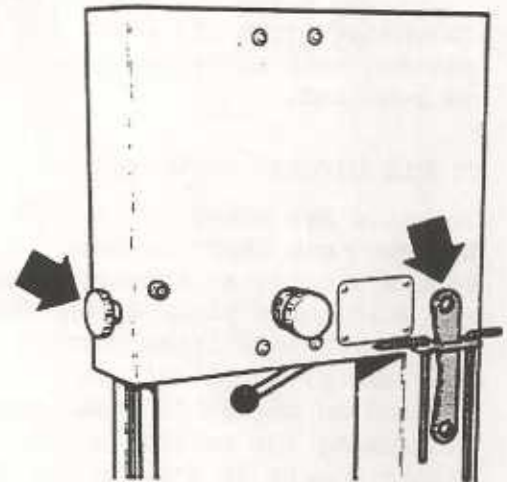

Fig.13.

CUTTING :

Before starting the machine, check it is safe to do so. Make sure that all necessary adjustments have been completed and all guards are in position and secure. The switch incorporates overload protection. If the machine is overloaded the switch will automatically cut-out and stop the machine. In such cases remove workpiece, wait a few minutes and re-start the machine allowing it to run without any load. Proceed as before but using less force.

OPERATING INSTRUCTIONS (CONTINUED).

RIIP FENCE & DEPTH STOP :

Fig.14 shows the rip fence and depth stop in use. They are very useful accessories which widens the scope of the machine considerably, as apart from straightforward ripping it makes possible the production of tenons of consistent thickness. When cutting several tenons of the same thickness, set the fence and depth stop, produce the required shoulder dimension and make a single saw cut in each piece, so as to produce one flank of the tenon. Re-set the fence to produce a tenon of the correct thickness, making sure that the same face of the workpiece is against the fence as when making the first cut. In this way, any variation in the width of the workpiece will not affect the finished width of the tenon. With the rod removed, the depth stop can be swung aside when not required.

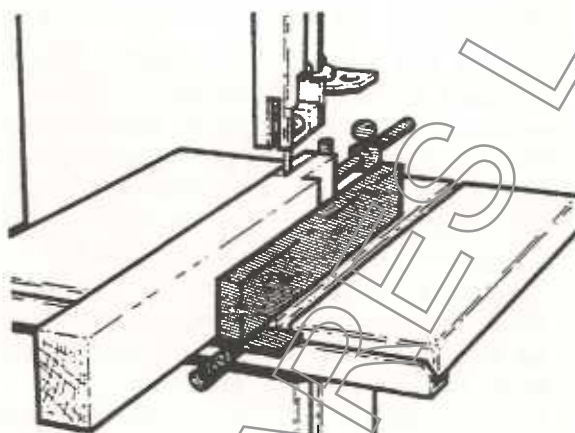

Fig.14.

MITRE GAUGE :

Fig.15 shows the mitre gauge in use on the machine. Locate mitre gauge into slot in table, set to required angle and position workpiece. Start machine, hold workpiece firmly against mitre gauge and slide along slot in table. Compound mitres are also possible by setting both mitre gauge and table tilt as required.

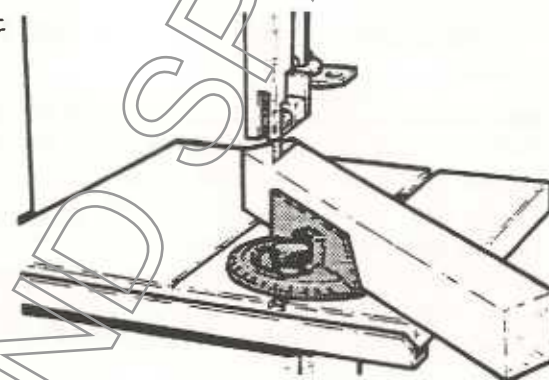

Fig.15.

CIRCLE CUTTING ATTACHMENT :

Select a saw blade to suit the circle to be sawn (see Chart on page 15). The circle cutting attachment is secured to the guide post plate as shown in Fig.16. This makes repetition cutting of blanks easy as the whole unit is raised and lowered on the guide post, thus avoiding disturbing the setting of the rod. The

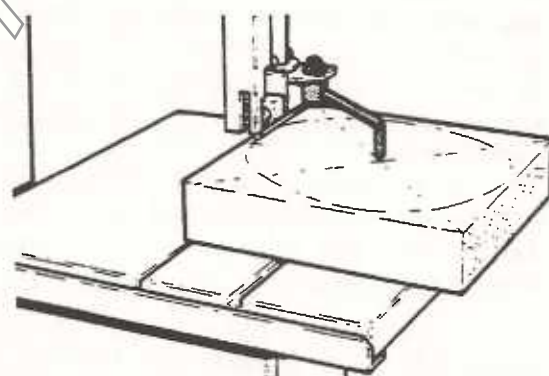

Fig.16.

blanks should be made in the shape of a square just a little larger than the diameter of the proposed circle and the centre and diameter marked. It is important that the centre of the circle is level with the front edge of the saw blade. To achieve this place rip fence against blade, mark position of front of blade on top of fence and move fence so that distance between blade and fence is equal to required radius. Set rod to mark on fence and secure in place. Remove rip fence and raise tool post so rod is clear of workpiece. Produce cut parallel with one side of square and stop when cut meets drawn circle as shown in Fig.16. Lower guide post until point on rod touches workpiece at centre of circle, tap rod gently into workpiece, lock tool post and cut out complete circle.

MAINTENANCE.

NOTE : ATTENTION TO MAINTENANCE WILL BE REPAID BY MANY YEARS' TROUBLE-FREE OPERATING.

MONTHLY :

- 1 - Remove imbedded chips from bandwheel tyres, check for wear and replace as necessary. Adjust wheel brush as required.
- 2 - Clean and check upper and lower blade guard assemblies. Replace worn parts as required. Check guide settings, and adjust if necessary (see pages 7 & 8).

GENERAL :

- 3 - Frequently check that dust outlets in base of machine are not clogged and clean out as necessary.

The bearings on the upper and lower bandwheel hubs are pre-packed with grease and do not require further maintenance.

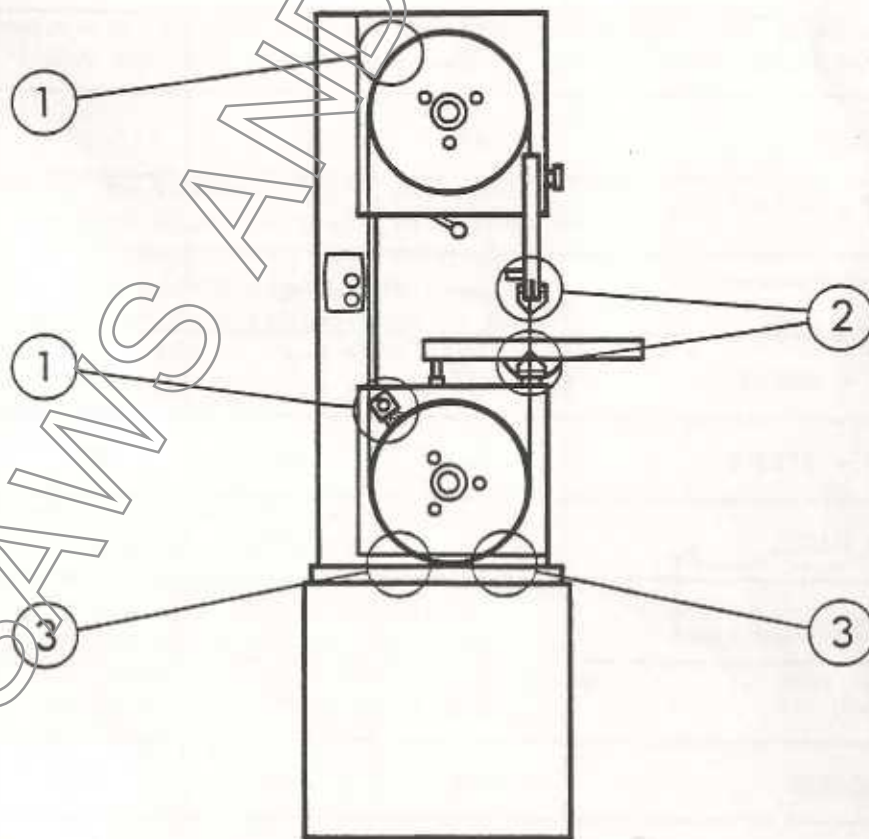

Fig.17 : Maintenance Points.

SAW TYPE SELECTION CHART

MATERIAL	MATERIAL THICKNESS			
	UNDER 6 mm, ¼"	6 mm, ½" TO 12 mm, ½"	12 mm, ½" TO 25 mm, 1"	OVER 25 mm, 1"
ALUMINIUM SECTIONS	18R	10R	8R	6S
BAKELITE	14R	10R	6R	3S
BONE	10R	8R	6R	3S
CARDBOARD CORRUGATED	SC	SC	SC	SC
CHIPBOARD		6S	3S	3S
CORK	14R	6R	3R	3R
FIBRE BOARD	18R	14R		
FORMICA	18R			
HARDBOARD	10R			
LEATHER	14R			
LINEN	KN	KN	SC	SC
PAPER - SHEET	10R	6S		
PAPER - TISSUE	SC	SC	SC	
PAPER MACHE	KN	10R		
PERSPEX	14R	10R		
PLYWOOD	10R	8R	6S	3S
STRAWBOARD	14R	10R	8S	6S
WOOD - LOG				3S
WOOD - HARD & SOFT	6S	3S	3S	3S

NUMBERS DENOTE TEETH PER INCH R = REGULAR TOOTH S = SKIP TOOTH
 SC = SCALLOPED EDGE KN = KNIFE EDGE

BANDSAW BLADES.

An understanding of the design and application of the various types of saw blades obtainable is essential if the bandsawing technique is to be fully exploited. Selection of the most suitable saw blade for the job is very important as a poor choice can lead to much wasted time and money.

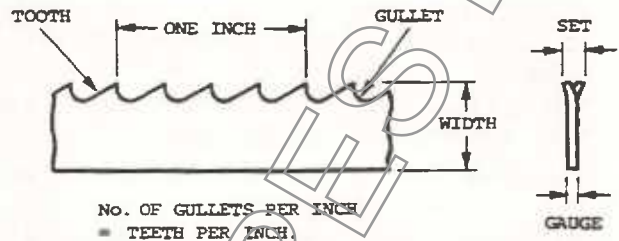

TOOTH PITCH is important if optimum blade performance is to be obtained. Tooth pitch is determined mainly on the basis of material thickness and to some extent on material hardness. For a given material thickness, a tough or abrasive material will require more teeth in engagement than a soft ductile one. Too many teeth in engagement will decrease the tooth loading to the point where the teeth cannot penetrate the material and so skid across the cutting face.

TOOTH FORM refers to the profile of the tooth. The two most popular styles are regular tooth and skip tooth as shown in the illustrations.

REGULAR TOOTH is the standard style for most saw blades. The zero front rake and well rounded gullets present a robust tooth with good shock resistance and work penetration properties. It will produce accurate fine finish work in most hard materials but tends to clog when used on soft materials. Standard pitches are 6, 8, 10, 14 & 18 teeth per inch.

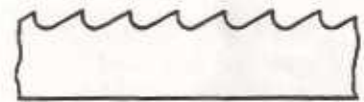

REGULAR TOOTH

SKIP TOOTH form is similar to the regular tooth form but alternate teeth are omitted, a design which allows greater gullet capacity without unduly weakening the body of the blade. Providing the thickness of the material permits, a skip tooth saw blade will give best performance on aluminium and soft alloys. Standard pitches are 3, 4 & 6 teeth per inch.

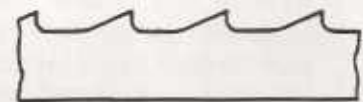

SKIP TOOTH

BANDSAW BLADES (CONTINUED).

HOOK TOOTH form has positive front rake which considerably assists work penetration and hence produces faster cutting times on harder materials. The coarse pitch and large gullets associated with this type of saw blade make it particularly suitable for sawing deep sections. However, it is not recommended for use on abrasive materials. standard pitches are 2, 3, 4 & 6 teeth per inch.

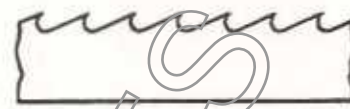

HOOK TOOTH

TOOTH SET is the angling of the saw blade teeth so that the tips protrude beyond the body of the saw blade. The width of the saw cut produced provides the working clearance necessary for the body of the saw blade and permits some degree of steering to negotiate curves.

STANDARD SET teeth are set alternately to the left and to the right, a style which is popular for cutting soft materials and wood.

RAKER SET saw blades have one tooth set to the left and one tooth set to the right, followed by one unset tooth. This style of set is widely used and is to be preferred for contour sawing.



RAKER SET



WAVY SET

WAVY SET saw blades have the teeth alternately set to the left and right in groups or waves. With this formation of tooth set, relatively few teeth are cutting at the side of the kerf and therefore there is some tendency for the saw blade to jam when sawing abrasive materials.

SAW GAUGE is the actual thickness of the body of the saw blade. Some manufacturers produce special gauge saw blades for specific purposes, but generally saw blades up to and including $\frac{1}{2}$ " wide are .025" thick and $\frac{3}{8}$ " wide are .032" thick.



KNIFE EDGE BAND



SCALLOPED EDGE BAND

Knife edge bands are suitable for cutting soft materials such as woven fabrics, sponge, rubber, and corrugated cardboard. Where the nature of the material is fibrous and difficult to sever, wavy or scalloped edge blades are better as the teeth provide a more positive cutting action. Typical applications are cutting cork, filter elements and felt etc. Because these bands separate the material, no dust or swarf is produced and a smooth finish is usually obtained.



WAVY EDGE BAND

BANDSAW BLADES (CONTINUED).

Sometimes even though the machine appears to be in good working condition, the saw blade persists in wandering from the true path of the cut. This is usually due to the workpiece being forced into the saw blade at a greater pace than the saw blade can cope with, or the teeth of the blade are not evenly sharpened and set. Repeat the cut using less feed pressure. If this does not cure the trouble, replace the saw blade.

NOTE : 'Hardedge' saw blades cannot be resharpened, but the teeth of wood cutting saw blades may be dressed by the following method :-

The saw blade should be sharpened square across and without hook, i.e. the front face of the hook square to the flank of the saw blade. The stroke of the file should be one smooth movement using the whole cutting length of the file and maintaining even pressure from start to finish. Mark the starting point for easy identification and proceed around the saw blade using one stroke per tooth. Should one stroke not be sufficient to produce a sharp tooth, go around the saw blade a second time in preference to repeated strokes to each tooth at one setting. It is important to maintain the correct size and shape of each tooth to avoid weakening the saw blade by forming a sharp corner in the gullet.

It is essential to use a genuine bandsaw file which has three sides and well rounded corners, the normal small file not being suitable. The purchase of a saw vice will prove a real asset as the long jaws permit about 18" or so of the saw blade to be sharpened at one setting.

A saw blade should be re-sharpened as soon as the teeth lose their fine point. Dull teeth tear the fibres of the wood instead of severing them cleanly and the increased feed pressure thus required produces a ragged inaccurate cut and considerably shortens the life of the saw blade.

The saw blade must be in reasonable condition to warrant re-sharpening. A saw blade that shows signs of fatigue, i.e. cracks at the gullets of the teeth, or one that has come into contact with a nail will not usually justify any further effort being expended on it and is best discarded.

Usually it is not necessary to re-set the teeth of the blade as the initial set will last for several sharpenings. The correct amount of set is about .005" each side and adjacent teeth are set in opposite directions. It is important that the saw blade be sharpened after it has been set.

Welding units and brazing units are available for repairing saw blades, or making blades from bulk coil and details of these units will be sent upon request.

BANDSAWING PRACTICE.

Having selected the best saw blade for the job, the most important rule to follow is to allow the saw blade to cut freely. Forcing the workpiece into the saw blade produces a ragged inaccurate cut and considerably reduces the working life of the saw blade.

For contour sawing the width of the saw blade must be chosen with regard to the smallest radius to be sawn, thus a small radius will demand the use of a narrow saw blade. The beam strength and permissible tension decreases rapidly for narrow saw blades and it therefore follows that narrow saw blades are particularly sensitive to excessive stress which will cause stretching and premature breakage through fatigue at high speed. Saw blades which fail through abuse of this kind are useless and must be discarded although the teeth may still be in good condition. It is impossible to be precise as to the smallest radius any given saw blade will cut as so much depends on job conditions and the skill of the operator, but the Chart on page 16 offers a basic guide on this point.

BLADE WIDTH SELECTION CHART

BLADE WIDTH		3 mm, $\frac{1}{8}$ "	6 mm, $\frac{1}{4}$ "	10 mm, $\frac{3}{8}$ "	12 mm, $\frac{1}{2}$ "	15 mm, $\frac{5}{8}$ "	20 mm, $\frac{3}{4}$ "
MINIMUM CURVE RADIUS	mm	8	25	38	62	100	136
	ins	$\frac{5}{16}$	1	$1\frac{1}{2}$	$2\frac{1}{2}$	4	$5\frac{3}{8}$

Several drilled holes at strategic points around the contour may be necessary to negotiate small radii or cut to a sharp corner. Experiment may show that it is advantageous to use a wood cutting blade with increased set when sawing small radii as the increased width of kerf allows the blade more freedom to follow a tight curve. It should be kept in mind, however, that the greater the set the more power is required to make the cut, and hence due care must be exercised to avoid working the saw blade beyond its limit.

It is often found that when cutting a scroll or similar shape the forward cut cannot be completed and the workpiece must be backed off the saw. Care is necessary here to ensure that the wood is backed out gently, and turned at the same time so that the kerf is always in line with the saw. When removing large pieces of waste material, make the shorter end first to avoid backing out of the longer cut.

Three dimensional shapes are easily produced on the bandsaw. A suitable block of square or rectangular section is prepared with the front and side profiles marked out on adjacent faces. Make all the necessary cuts on one face and carefully replace the waste pieces in position. Turn the block on its side and cut out the second profile. With some jobs of this nature it may prove useful to tape the waste pieces in position to retain the block profile for ease of handling.

BANDSAWING PRACTICE (CONTINUED).

Light metals must always be sawn with a 'Hardedge' saw blade. Some aluminium alloys tend to clog the blade teeth but an occasional application of lubricant in the form of paraffin or wax should solve this problem.

Very little difficulty will be experienced in cutting solid plastic materials although some have an abrasive nature which tends to shorten the effective life of the saw blade.

Heat generated by sawing friction cause thermoplastic materials to become sticky and there is a marked tendency for the saw blade teeth to be clogged by swarf, particularly when blunt or fine pitch saw blades are used. The tendency to clog can be reduced by lubricating the saw blade with water or wax.

Some materials, the thermosetting phenolics in particular, give off a toxic airborne dust and in order to avoid possible risk to health, advice on dust extraction should be obtained.

A.L.T.

SAWS AND SPARES

LTD

COMMON SAWING PROBLEMS.

BLADE WANDERS FROM TRUE LINE :

Excessive feed pressure.
Blade teeth dull or of too fine pitch.
Guide inserts not controlling blade through wear or incorrect adjustment.
Blade tracking incorrect.
Loss of set to one side of saw teeth.

PREMATURE BLADE BREAKAGE :

Excessive feed pressure, and/or too much blade tension.
Worn or incorrectly set guides.
Joint improperly welded and annealed.
Blade too wide for curved cut.
Bandwheels worn.
Blade teeth of too fine pitch.

BLADE BOWS IN DEEP CUT :

Excessive feed pressure.
Blade teeth dull or of too fine pitch.
Insufficient blade tension, and/or blade too narrow for depth of cut.
Blade running off at start of cut.

BLADE TEETH DULL RAPIDLY :

Insufficient feed pressure.
Guide inserts snagging set of teeth.
Blade speed too fast, and/or blade pitch too fine.
Hard spots in material.

TEETH TORN FROM BLADE :

Excessive feed pressure.
Gullets of teeth loading.
Blade speed too fast, and/or blade pitch too coarse.
Material pressure welding to teeth.

BLADE DEVELOPING TWIST :

Excessive feed pressure.
Guide inserts snagging blade.
Blade too wide for radius of cut.
Excessive blade tension.
Blade not tracking correctly.
Loss of set to one side of saw teeth.

BLADE VIBRATES IN CUT :

Workpiece not properly seated or securely held.
Blade speed too fast, and/or blade pitch too coarse.
Insufficient blade tension.
Blade not backed up by guide thrust pads.

UPPER ASSEMBLY / TRACKING HUB ASSEMBLY - ASSEMBLY No. SM1669

NOTE, SM1669 Nos, 1-5, 26-30 & 37 ONLY.

ITEM	PART NUMBER AND DESCRIPTION	No.OFF
1	6701 Bandwheel Spindle	1
2	Thrust Washer	2
3	Drawn Cup Needle Roller Bearing	2
4	6700 Bandwheel Hub	1
5	External Circlip	1
6	Washer	19
7	Hex. Screw	7
8	2473 Bandwheel	1
9	SM1667 Top Guard	1
10	4891 Blade Guide	2
11	Hex. Nut	11
12	6756 Table Insert	1
13	4919 Washer	1
14	Coach Bolt	2
15	SM1434 Guide Bracket	1
16	5060 Washer	1
17	Hex. Screw	1
18	5496 Guard Handle	1
19	5313 Modified Cap Screw	2
20	Soc. Set Screw	1
21	4889/2 Top Guide Post	1
22	Spring Flexo	1
23	4988 Special Nut	1
24	SM862 Clamping Handle	1
25	Coach Bolt	4
26	6705 Pivot Pin	1
27	Starlock Washer	2
28	SM1676 Tracking Channel	1
29	Washer	1
30	Self Locking Nut	1
31	4902/1 Tension Screw	1
32	7805 Trunnion Nut	1
33	8315 Slotted Nut L.H. Thread	1
34	Washer	3
35	7834 Spring Plate	1
36	Disc Spring	22
37	SM1675 Guide	1
38	Ball Knob No. [redacted]	1
39	Sel Lok Pin [redacted]	1
40	6706 Tracking Lock Knob	1
41	5352/1 Studding	1
42	Hex. Locknut [redacted]	1
43	Handknob [redacted]	1
44	7835 Captive Thumb Screw	1
45	SM1665 Top Door	1
46	7354 Tension Indicator Plate	1
47	7839 Bush	1
48	Hex. Hd. Screw [redacted]	1
49	Washer [redacted]	3
50	Self Locking Nut [redacted]	1
51	7878 Tension Plate	1
52	Hex. Nut [redacted]	4

A.L.T. SAWS & SPARES LTD
 (Starrite Machine Specialist)
 Unit 15 Pier Road Industrial Estate
 Gillingham
 Kent
 ME7 1RZ
 Tel/Fax: 01634 850833
 www.altsawsandspares.co.uk

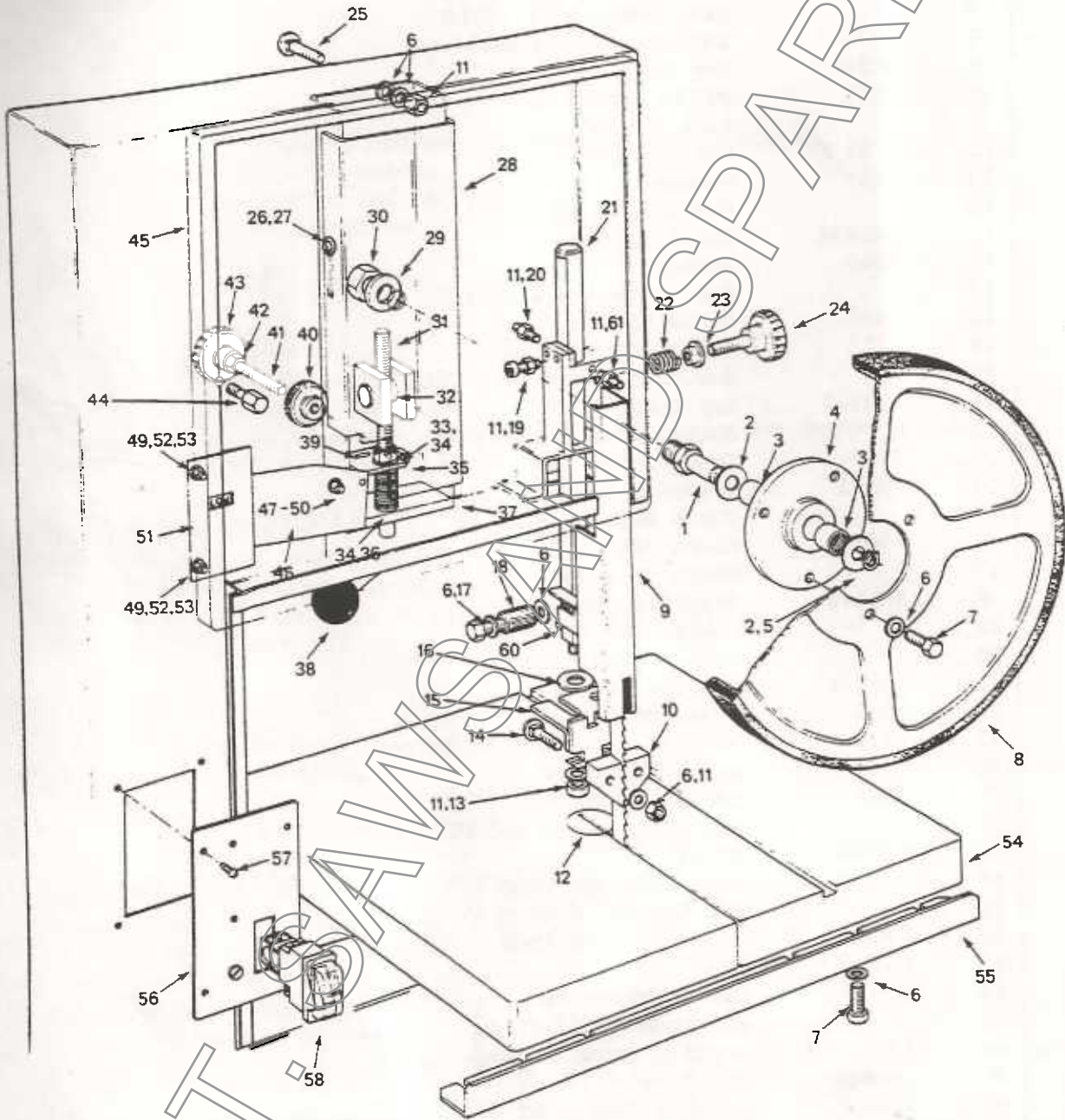

UPPER ASSEMBLY/TRACKING HUB ASSEMBLY

LOWER ASSEMBLY/MOTOR PLATFORM ASSEMBLY

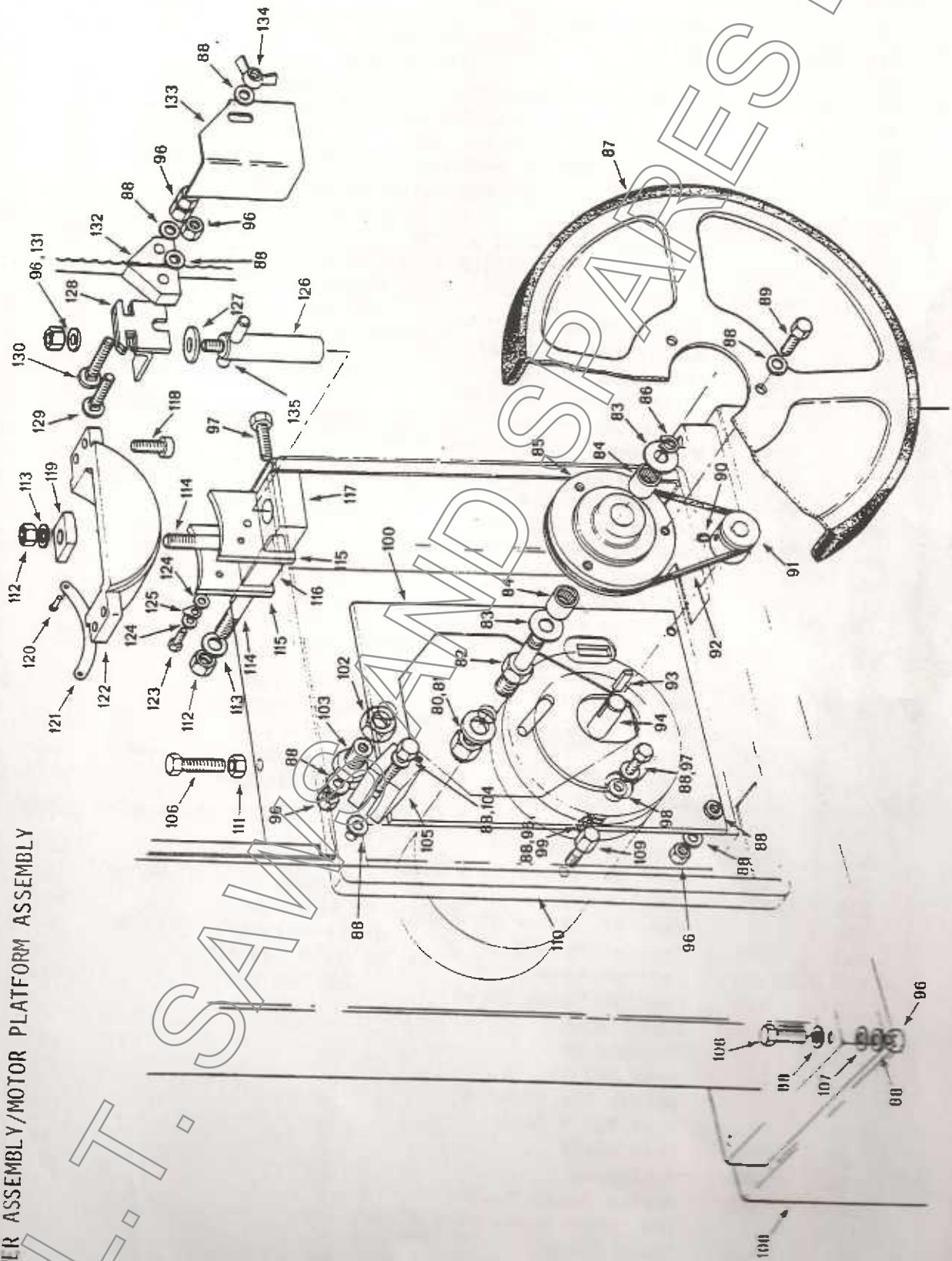

UPPER ASSEMBLY (CONTINUED).

ITEM	PART NUMBER AND DESCRIPTION	No. OFF
53	Locking Washer	2
54	SML392 Table	1
55	7353 Fence Rail	1
56	SML671 Control Panel Assembly	1
57	Phil Self Tapping Screw	4
58	Starter WTNL	1
59	Flush Mounted Starter Switch for 3 Phase Machines. (Not Illustrated).	1
60	SM585/1 Thrust Rod Top	1
61	Soc. Set. Screw	1
LOWER ASSEMBLY/MOTOR PLATFORM ASSEMBLY SM1670 & SM1670/3		
NOTE:- SML670 Nos. 80 - 86, 90 - 94, 100, 102, 103.		
80	Self Locking Nut	1
81	Washer	1
82	6701 Bandwheel Spindle	1
83	Thrust Washer	2
84	Drawn Cup Needle Roller Bearing No.	2
85	7796 Bandwheel Pulley	1
86	Circlip External	1
87	2473 Dia Bandwheel	1
88	Washer	27
89	Hex. Hd. Screw	3
90	Soc. Set. Screw	1
91	7797 Motor Pulley	1
92	Polyflex Vee Belt	1
93	Motor Shaft Key	1
94	Motor	1
96	Hex. Nut	14
97	Hex. Hd. Screw	4
98	7826 Spacer	3
99	Lock Washer	3
100	7840 Motor Platform	1
102	Hex. Locknut	1
103	7824 Jacking Bolt	1
104	Hex. Hd. Screw	1
105	2270 Wheel Brush	1
106	Hex. Hd. Screw	5
107	6942 Special Washer	4
108	SML668 Cabinet Base	1
109	7835 Captive Thumb Screw	1
110	SML666 Lower Door	1
111	Locknut	1
112	Hex. Nut	3
113	Washer	3
114	Stud	3
115	4884 Tilt Plate	2
116	4885 Spacer	1
117	4890 Bottom Guide Holder	1
118	Soc. Cap. Screw	4
119	4911 Table Clamp	1
120	Hammer Drive Screw	2
121	4921 Protractor Plate	1

LOWER ASSEMBLY (CONTINUED).

ITEM	PART NUMBER AND DESCRIPTION	No. OF
122	4838 Table Bracket	1
123	Hex. Hd. Screw	1
124	Washer	2
125	2812 Pointer	1
126	4888 Bottom Guide Post	1
127	5060 Washer	1
128	SM829'2 Guide Bracket Assembly (Lower)	1
129	Coach Bolt	1
130	Coach Bolt	1
131	4919 Washer	1
132	4891 Blade Guide	2
133	6748 Bottom Guard	1
134	Wing Nut	1
135	SM585/2 Thrust Rod Bottom	1
RIP FENCE - ASSEMBLY No. SM1435		
150	SM1433 Rip Fence	1
151	6728 Thumb Screw	1
CIRCLE CUTTING ATTACHMENT - No. SM1437		
152	M8 Full Nut	1
153	4919 Washer	1
154	6746 Clamping Sleeve	1
155	6744 Centre Rod	1
156	6745 Clamping Bolt	1
MITRE GAUGE - ASSEMBLY No. SM1432		
157	211 Guide Strip	1
158	126 Thumb Screw	1
159	6749 Back Stop Rod (Found on SM1436)	1
160	6234 Thumb Screw	1
161	Protractor	1
DEPTH STOP - ASSEMBLY No. SM1436		
162	Coach Bolt	1
163	6749 Back Stop Rod	1
164	Wing Screw	1
165	6747 Clamping Block	1
166	Washer Form	1
167	Wing Nut	1

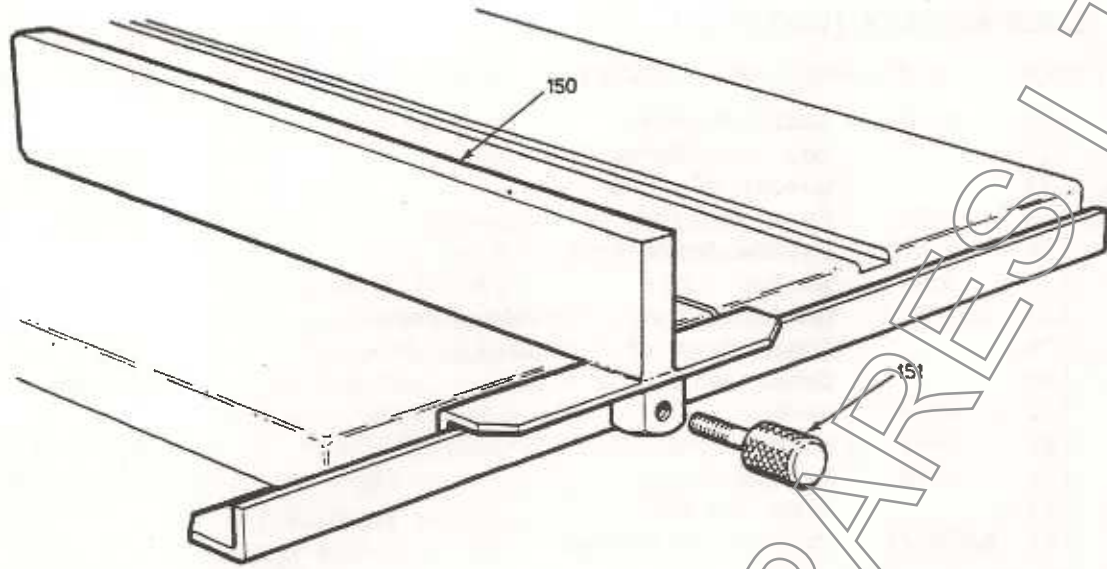

RIP FENCE
ASSEMBLY No. SM.1435

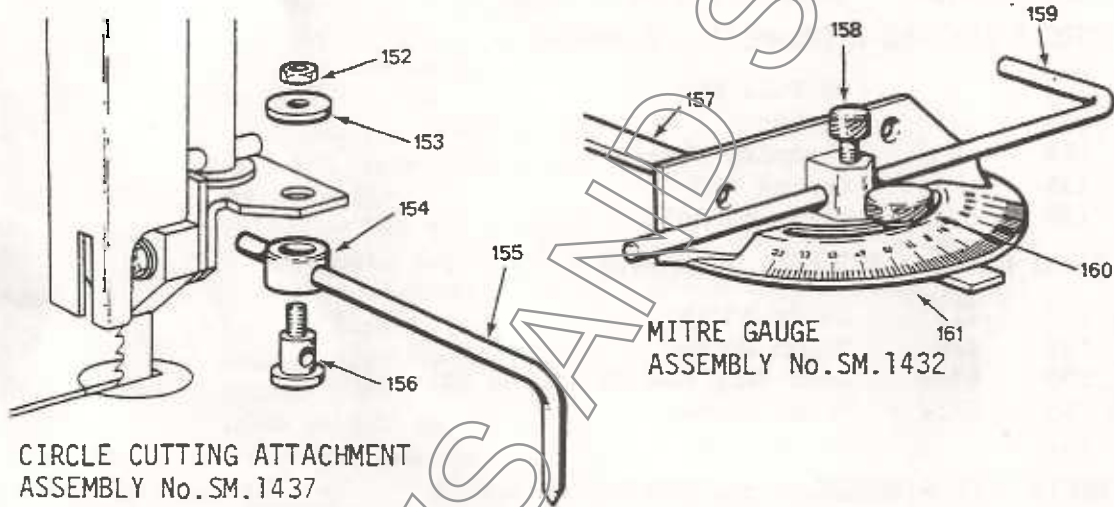

CIRCLE CUTTING ATTACHMENT
ASSEMBLY No. SM.1437

MITRE GAUGE
ASSEMBLY No. SM.1432

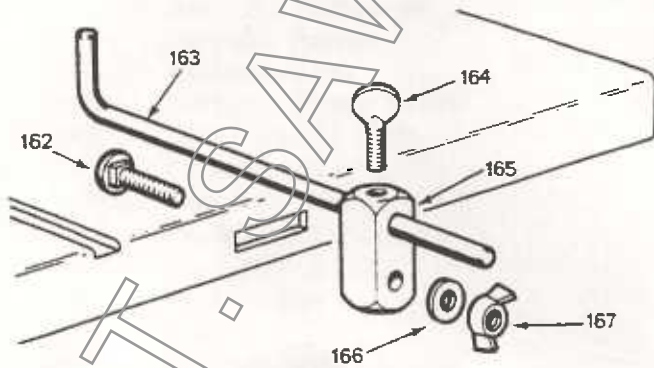

DEPTH STOP
ASSEMBLY No. SM.1436

OPTIONAL EXTRAS AND ACCESSORIES.

- 168 'Cyclair' Extraction Unit - 1 Phase
'Cyclair' Extraction Unit - 3 Phase
- 169 SMI393 Dust Extraction Unit to be coupled directly to machine.
- 170 Model B15 Bandsaw brazer unit, for joining blades up to 5mm wide from bulk coil stocks.

NOT ILLUSTRATED :

bandsaw blades joined ready for use, 102" long.
(Also available in 100' coils).
Wood & Metal cutting saw blades available in various pitches:-
 $\frac{1}{8}$ ", $\frac{3}{16}$ ", $\frac{1}{4}$ ", $\frac{3}{8}$ ", $\frac{5}{8}$ " & $\frac{3}{4}$ " wide.

A.L.T. SAWS AND SPARES LTD

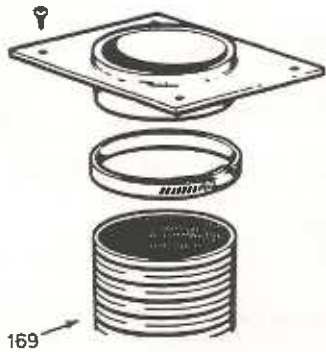

DUST EXTRACTION COUPLING ADAPTOR

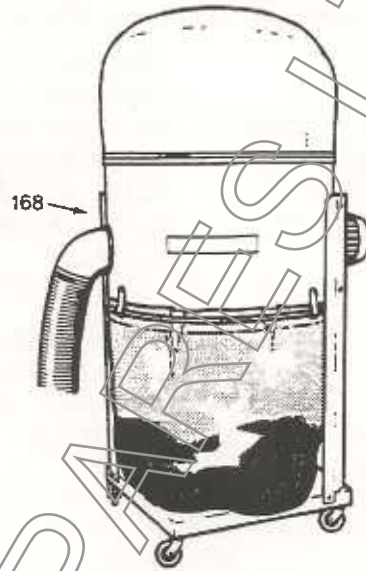

'CYCLAIR' EXTRACTOR UNIT

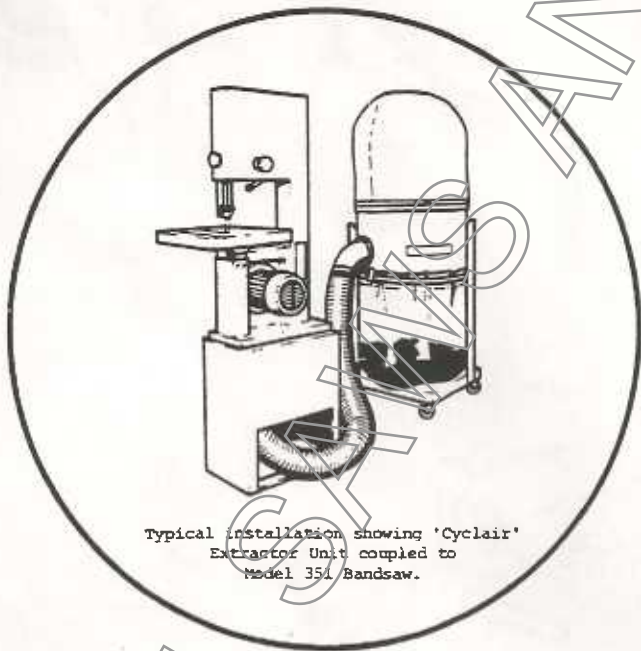
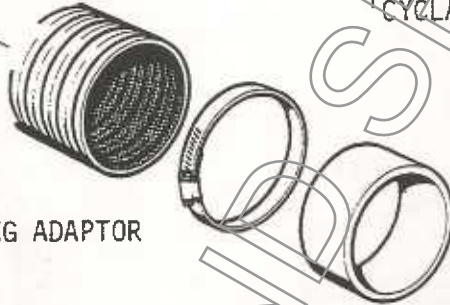

Typical installation showing 'Cyclair' Extractor Unit coupled to Model 351 Bandsaw.

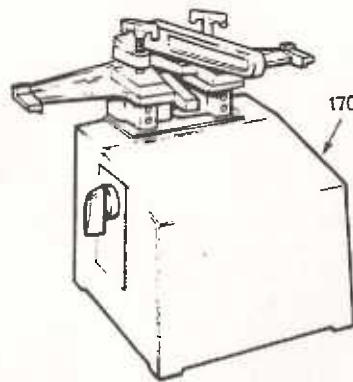

BANDSAW BRAZER

OPTIONAL EXTRAS & ACCESSORIES